

**INTROTEK**

Excellence in Ultrasonic Technology

**AMETEK**

introtek.com



# Continuous Level Detector (CLD) Non-invasive Sensor

The **Introtek® Continuous Level Detector (CLD)** is a unique pulsed ultrasonic, non-invasive sensor used to accurately monitor liquid levels from the bottom of a vial, container, or tank.

Scalable for small to large containers or vessels, this sensor is available in a standard configuration or can be customized to meet specific application requirements.

Introtek's patented pulse-type ultrasonic technology is renowned for its exceptionally reliable, non-invasive liquid level and air detection capabilities. Used in the most critical applications where patient or process safety is mandatory, pulse-type technology greatly reduces or eliminates many of the variables that affect the accuracy of amplitude based or continuous-wave ultrasound.

## PRODUCT FEATURES

- Customizable for a wide range of container/vessel diameters, depths, and variations
- Reliable pulse-type, non-invasive technology with electronics options per your specifications
- Continuous analog output signal pinpoints precise liquid levels
- Integrated electronics; no remote electronics board required
- Dry coupled; no coupling gel required
- Space-saving interface design; simple uni-body construction with no moving parts
- High noise immunity to EMI and RFI
- Factory-calibrated and maintenance-free

Continuous Level Detector (CLD)



## APPLICATIONS

- Medical Related Equipment
- Improves Processes for:
  - Liquid dispensing
  - Reagent & vaccine production
  - Pharmaceutical manufacturing
  - Clinical laboratory testing
  - Chromatography
  - 3D printing and ink processing machines
  - Food & beverage production



## The Introtek Advantage

Introtek provides products of unsurpassed quality, functionality, and dependability. They are manufactured to the highest medical device standards and are backed by a three-year warranty.

### FUNCTIONAL SPECIFICATIONS

Analog Output	Standard factory analog output calibrations are set as follows: <ul style="list-style-type: none"><li>• 5VDC Input = 0 to 5VDC Output (or as required)</li><li>• 12VDC Input = 0 to 5VDC Output (or as required)</li><li>• 24VDC Input = 0 to 5VDC Output (or as required)</li></ul> The sensor may be programmed for custom full scale output voltages offsets, and logic thresholds. This calibration is performed at the factory via special order. Custom timing and averaging are also available.
Logic Output	The Logic Output shall provide a logic high output when the liquid level reaches or exceeds the pre-calibrated set point. Set point threshold as per customer requirement.
Operating Temperature	+41 to +140 °F (+5 to +60 °C)
Humidity: 0% to 95% Non-Condensing	

Please contact an Introtek application specialist to determine the optimal configuration for your application.

### AVAILABLE OPTIONS

- Sensor arrays
- Continuous level detection
- Full-scale output
- Custom OEM designs

### MECHANICAL SPECS

Dimensions in millimeters (inches)

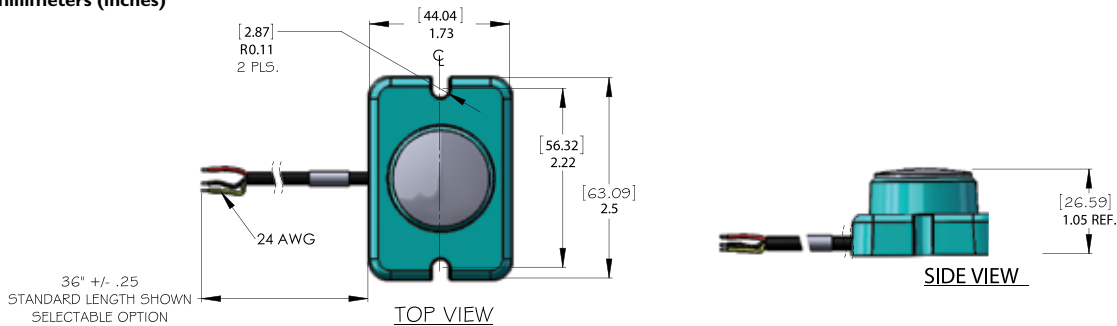

### VALIDATION TESTING

The CLD Sensor was designed to meet validation requirements in conjunction with the following specifications:

- Electrical Fast Transients: IEC 61000-4-4:2012
- Radiated Emissions, Group I, Class B: CISPR 11
- Electrostatic Discharge: IEC 61000-4-2:2008
- Radiated Immunity: IEC 61000-4-3:2020
- Power Frequency Magnetic Fields: Performed per IEC 60601-1-2:2020
- General Safety Requirements: IEC 60601-1, 3.2 Edition

### THREE-YEAR WARRANTY

All Introtek systems are warranted free of defects in materials or workmanship for three full years from the date of original factory shipment.

If returned within the warranty period, with no modifications to the sensor, the original manufacturing label intact, and, upon factory inspection of the unit, the cause of the malfunction is determined to be defective material or workmanship, Introtek will repair or replace the system at no cost to the purchaser (or owner) other than transportation. **If a unit is returned without an original label, the warranty is void.**

Introtek shall not be liable for misapplication, labor claims, direct or consequential damage or expense arising from the installation or use of the equipment. There are no other warranties expressed or implied except special written warranties covering some Introtek products.

**INTROTEK** / **AMETEK**<sup>®</sup>

Excellence in Ultrasonic Technology™

150 Executive Drive • Edgewood, New York 11717-9998  
631-242-5425 • [www.introtek.com](http://www.introtek.com) • [info.introtek@ametek.com](mailto:info.introtek@ametek.com)

Copyright © 2022 AMETEK Magnetrol USA, LLC

Performance specifications are effective with date of issue and are subject to change without notice.



Bulletin: 90-155.1  
Effective: April 2022