

IQRF HW design

for TR-7xD transceivers

Application note AN015



Smarter Wireless. Simply.

Content

| | | | |
|---|----|---|----|
| 1 Power supply | 3 | Hint | 11 |
| LDO regulator | 3 | 5 RF aspects | 12 |
| TRs with LDO | 3 | RF range | 12 |
| TRs without LDO | 3 | Antenna design..... | 12 |
| Decoupling..... | 4 | Antenna connector | 12 |
| Filtration..... | 4 | Antenna cable..... | 13 |
| Other hints | 4 | RF self-noise | 13 |
| Disconnecting | 5 | 6 PCB design..... | 14 |
| HW TR reset..... | 5 | Footprint | 14 |
| Undervoltage | 5 | Recommended PCB layout | 14 |
| Undervoltage detection..... | 5 | Antenna connector layout..... | 14 |
| Power consumption measurement | 6 | 3D models | 14 |
| Precise | 6 | 7 SMT mounting | 15 |
| Improvising..... | 6 | Rules and recommendations for SMT mounting..... | 15 |
| 2 I/O pins | 7 | Base PCB..... | 15 |
| MCU-depended pin features..... | 7 | Baking | 15 |
| Internal pull-up resistors | 7 | Assembly..... | 15 |
| Multiplexed pins and protective resistors | 7 | Reflow profile..... | 15 |
| LED pins | 7 | 8 Sealing | 16 |
| Pins to switch to programming mode..... | 8 | 9 Case | 16 |
| SPI pins | 8 | 10 Recommended documentation..... | 17 |
| SPI communication..... | 8 | 11 Document revision..... | 17 |
| Upload and debug | 8 | 12 Sales and Service..... | 18 |
| A/D pins | 8 | Corporate office | 18 |
| IQuip prebonding tool | 8 | Technology and development..... | 18 |
| Unused pins..... | 8 | Partners and distribution..... | 18 |
| A do-not-use pin | 9 | Quality management..... | 18 |
| 3 TR upload..... | 10 | Trademarks | 18 |
| Wired in-circuit upload | 10 | Legal..... | 18 |
| Wireless in-circuit upload..... | 10 | On-line support | 18 |
| 4 Application circuitry..... | 11 | | |
| Non-SMT TRs | 11 | | |
| SMT TRs | 11 | | |

This document describes basic rules recommended for HW design with IQRF transceivers TR-7xDx.

1 Power supply

A properly designed power supply can prevent many troubles. It is doubly important if a switching power source or a DC/DC converter is used.

LDO regulator

TRs with LDO

Several TRs (e.g. [TR-72D](#) series) are equipped with internal LDO voltage regulators (linear, low drop-out). Required supply voltage (V_{IN}) must be from **3.1 V to 5.3 V**, not necessarily stabilized. The regulated LDO output voltage **+3 V \pm 60 mV** (for $V_{IN} > 3.1$ V) is primarily intended to supply internal TR circuitry ($V_{internal}$).

External LDO output

Additionally, the LDO output can also be used to optionally supply an external circuitry of the user equipment (up to 100 mA). To select this option, interconnect the S1 pads to each other by soldering. Of course, in this case, the given pin (e.g. C2 for [TR-72D](#)) cannot be used as a general-purpose I/O pin and the corresponding MCU pin (e.g. RC2 for [TR-72D](#)) must not be declared as output in the user application.

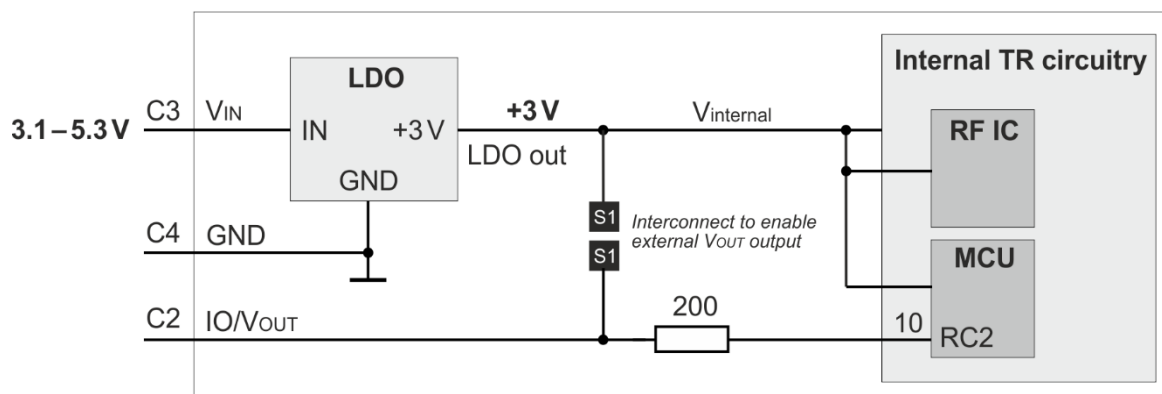

Fig.1: [TR-72D](#) power supply circuitry

TRs without LDO

Other TRs (e.g. [TR-76D](#) series) have no LDO regulator. Required supply voltage (V_{IN}) must be from **3.0 V to 3.4 V, stabilized**.

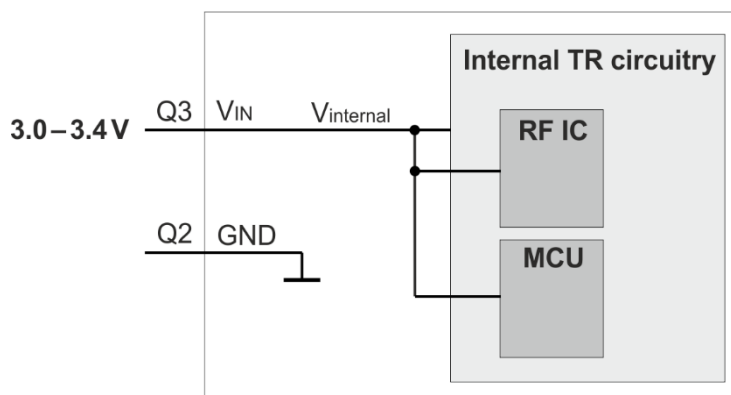

Fig.2: [TR-76D](#) power supply circuitry

Decoupling

The power supply must be designed according to standard rules for power sources. Decoupling and filtration must be used for stability and avoiding unwanted emissions. Especially for switching power supplies, DC/DC converters, frequency multipliers, etc., ripples and radiated noise at harmonic frequencies may lead to serious trouble. Pulsing power consumption during RF receiving and (especially) transmitting must also be taken into account. Power supply instability may affect not only the overall TR behavior but also RF functionality, RF parameters, and RF range.

The incoming power supply must be filtered by decoupling capacitor(s) positioned adjacent to TR power supply pins and connected to a nearby ground. The types and the values strongly **depend on the application** and should be selected in conformity with general rules for electronic design (according to the given power source, power-consuming parts, the inductance of PCB lines, etc.). More capacitors in parallel are often used, e.g. preferably a **tantalum** capacitor up to tens of μF , supplemented with a 100 nF to 1 μF **ceramic** one as close to the V_{IN} pin as possible. Optionally, possible fast transient currents can be decoupled by an additional low-capacity ceramic capacitor (e.g. even 10 pF to 22 pF to eliminate ripples from sub-GHz RF) and high but slow transient currents by a high-capacity **electrolytic low ESR** capacitor (e.g. one per board). All capacitors must be rated for at least 6.3 V when supplied from a low-ripple source like a battery or an external LDO but for higher voltage otherwise.

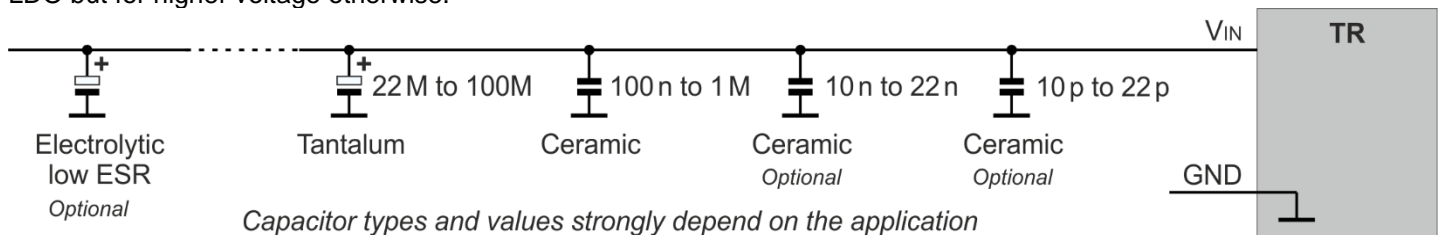

Fig.3: Example of decoupling

Filtration

Spreading of **transient current** (not only from RF output frequency) **via power lines** must be avoided. Therefore, general rules for reliable HW design of power supply must be observed. In addition to correct PCB layout, for demanding applications or applications in a harsh environment, the power source supplying the TR must be **filtered** properly.

The following example is only intended as a **general hint**. **The specific circuitry including component values strongly depends on the given application**. The entire filter circuit must be placed as close as possible to the TR.

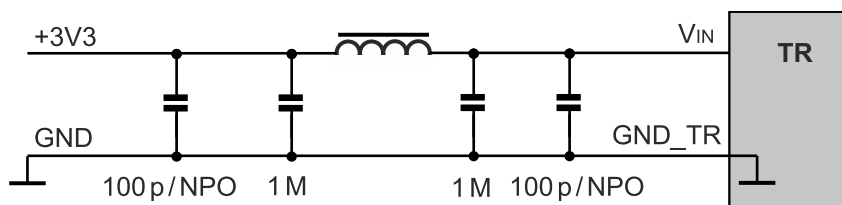

Fig.4: Example of filtration

Other hints

In doubts, additional precautions may help:

- It may be convenient to suppress the ripples by an **LDO** (even e.g. when a DC/DC converter is used).
- Additional **RF** (e.g. a **GSM** or **Wi-Fi**) may impact not only IQRF wireless but also the TR power supply quality. Thus, place RF antennas properly. If necessary, connect antennas via cables with sufficient length and proper impedance.
- The noise incoming from outside through communication wires can be eliminated by **optocouplers**.

Disconnecting

HW TR reset

If the TR is controlled by an external MCU, it is recommended to have an option to **disconnect** the power supply from TR and disconnect all TR pins from the application. This allows performing **HW reset** of TR in a reliable way. The solution depends on the application. As a last resort, disconnecting by control signal(s) can be performed using an additional HW, e.g. via a single-chip complementary power MOSFET pair AP2531GY-HF-3 and an analog switch like 74HC4066.

Among others, such an HW TR reset can be used to invoke **wired in-circuit upload**, see chapter [TR upload](#). Wireless in-circuit upload (RFPGM) does not require such disconnecting.

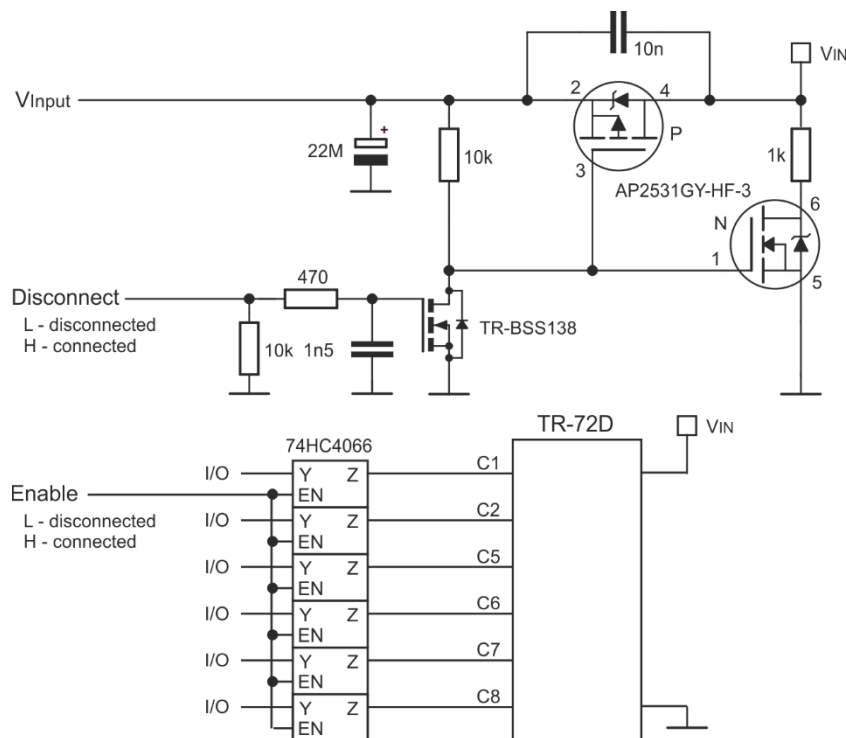

Fig.5: Example of TR-72D disconnecting

Undervoltage

All specifications declared in the [TR datasheet](#) (first of all the *Absolute maximum ratings* and the *Electrical specifications*) must be observed.

Even though all parts used inside the TR work below 3 V, it is **not allowed to operate the TR** itself with $V_{internal} < 3\text{ V}$ otherwise degradation of RF parameters including RF range may occur.

Caution: If V_{IN} drops under 3 V for [TR-72Dxx](#) and [TR-78Dxx](#), power consumption of on-board LDO increases from about 1.5 μA to about 18 μA .

Undervoltage detection

A low power supply voltage can be detected as follows:

- Only the internal power supply voltage ($V_{internal}$) **is checked**.
- In case of a TR with LDO, $V_{internal}$ is the **LDO output but not** the actual **battery voltage**. This value is 3.0 V typically if the battery is O.K. and drops down if the battery is low.
- To evaluate the battery condition, take into consideration your battery type and power supply circuitry with respect to the diodes and other possible voltage drops.

The check is not performed automatically but can be invoked in application SW whenever is needed.

For **C-programming** approach:

IQRF OS function `getSupplyVoltage()` is available. See [IQRF OS Reference guide](#).

For **DPA** approach:

- The Coordinator can monitor supplying of all Nodes using the [OS](#) peripheral and the [Read](#) command.
- When using the DPA value, information about the power supply is included in every [Response](#).

Power consumption measurement

Precise

To measure the TR power consumption, appropriate measuring equipment should be used. The Keysight N6705B DC power analyzer with N6785A source/measure unit for battery drain analysis is recommended.

Improvising

As an improvisation, a **precise multimeter** measuring a voltage drop on a resistor only can be used. However, this method should serve for very rough estimation only. The measuring equipment described here cannot substitute expensive instruments being able to evaluate precise values from non-periodical current waveforms.

Upload an appropriate SW (e.g. the basic example E14-CONSUMPTION included in [IQRF Startup package](#)) into the TR. Disconnect the power line supplying the TR inside your equipment and connect there the circuitry and the voltmeter according to the description and the schematics below. (E.g. for [DK-EVAL-04A](#) development kit, the measuring circuitry should be connected instead of the **jumper JP1** on this kit.)

A high capacity low impedance capacitor must be used for **integrative measurement** converting transient current to approximately steady voltage measurable by a voltmeter. The proper polarity with respect to the capacitor must be kept.

The PB1 pushbutton is intended to discharge the capacitor before every new measurement. Depending on the range of the current, one of the switches SW1 to SW3 must be selected as follows:

- SW1 In milliamperes (e.g. for TX or STD RX modes)
- SW2 Up to about 200 μA (e.g. for LP RX mode)
- SW3 Up to about 20 μA (e.g. for XLP RX or Sleep modes)

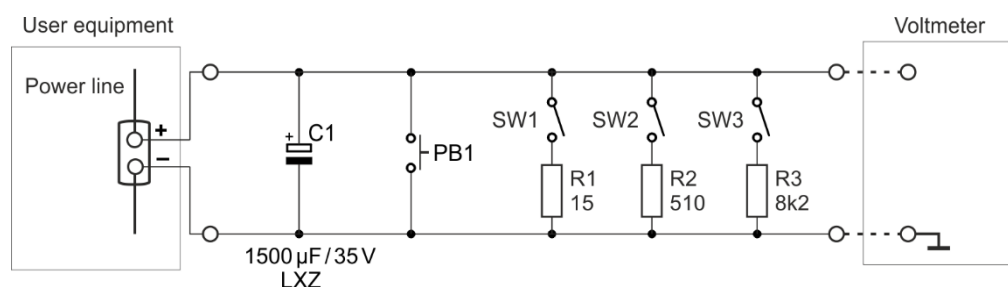

Fig.6: Improvising power consumption measurement

If the voltage oscillates (typically in LP and XLP RX modes), the voltage value should be read when the value is as stable as possible.

- The exact values of the resistors used should be evaluated for the current calculation.
- The leakage current of the capacitor in given conditions (temperature, etc.) should be known (evaluated separately) and then subtracted from the value measured.
- The power consumed by the LDO regulator inside the [DK-EVAL-04A](#) must be evaluated separately (without a TR) and then subtracted from the value measured.

2 I/O pins

See also chapter [Application circuitry](#).

MCU-depended pin features

- Individual I/O types (digital, Schmitt trigger or analog input, CMOS or analog output, ...) depend on given MCU pins and their particular configuration. In doubt, refer to the [MCU datasheet](#), chapter *Pinout description*.
- I/O pins are **not 5V-tolerant**. Input voltage on input pins must be in the range from **0 V** to **V_{internal}**.
- Depending on TR type, several I/O pins, e.g. C5 (MCU pin RB4) for [TR-72D](#) or Q12 (RB4) for [TR-76D](#) have **interrupt / wake-up on change** (IOC) ability. This should primarily be used e.g. to connect a pushbutton or another signal for awakening from sleep.
- Some additional requirements should be observed when utilizing peripherals inside the MCU (such as SPI, I²C, UART, PWM, A/D converter, D/A converter, or analog comparator). E.g., see chapters [SPI pins](#), [A/D pins](#), and [MCU datasheet](#).

Internal pull-up resistors

Depending on TR type, several I/O pins, e.g. C5 (MCU pin RB4) for [TR-72D](#) and Q12 (RB4) for [TR-76D](#) have SW selectable weak **pull-ups** with resistance typically about 30 k Ω at 3 V (rough value for guidance only). For more exact values refer to [MCU datasheet](#), *DC characteristic*, *Weak pull-up current* parameter. However, in some cases (e.g. for high communication speed or in a harsh environment), it may be convenient to use external pull-ups with lower resistance.

Multiplexed pins and protective resistors

- Non-solderable TRs (primarily intended for use in SIM connectors, e.g. [TR-72D](#)) have **multiplexed** up to 3 MCU I/Os on a single TR pin. This must be taken into account in application SW to avoid possible collisions.
- Non-solderable TRs have 200 Ω **protective series resistors** on each MCU pin. Solderable TRs (e.g. [TR-76D](#)) have not multiplexed MCU pins and no onboard series resistors. Thus, they should be equipped with an **external** protective resistor on each pin used. The recommended value is 200 Ω .

See *Simplified schematic* in [TR datasheet](#).

LED pins

Two MCU pins are dedicated to **LEDs**. They are primarily intended for OS and DPA “**system**” **indication** but can also be used for **user indication**. The LED implementation depends on the TR type:

- On-board LEDs, with externally not accessible pins (e.g. [TR-72D](#) and [TR-75D](#)).
- On-board LEDs, with externally accessible pins (e.g. [TR-77D](#)). This allows e.g. to connect additional external LEDs outside the product case.
- No on-board LEDs but externally accessible pins (e.g. [TR-76D](#)).

It is highly recommended to populate both LEDs on the user device. This is important for the “system” indication, especially during development and installation as well as for maintenance, troubleshooting, and technical support.

Pins to switch to programming mode

An **SDO - SDI** pair of TR pins (e.g. C8 and C7 for [TR-72D](#) or Q8 and Q7 for [TR-76D](#)) is used as the output and input during the initial approximately 200 ms **boot-up** (after power supply rising-up) to detect a possible request to enter the programming mode (**PGM** - wired upload via SPI). After reset, the OS generates a determinate sequence on the SDO pin. If this sequence is copied to the SDI, the OS jumps to the PGM bootloader. The PGM mode is indicated by short red LED flashing every 2 s. See chapter [TR upload](#) below.

This must be taken into account to avoid collisions and malfunctions with application circuitry connected to these pins. Among others, the SDO pin should not be used to control a device like a relay.

The SDI pin must not be interconnected to SDO or left unconnected or without a **defined level** on its input. This level must be arranged **by application hardware**. If the application circuitry ensures no such level, a **pull-down resistor on the SDI pin** must be used otherwise a **cross-talk** between SDO and SDI may cause an unintentional switching to PGM. See also [Fig.9](#).



Fig. 7: Example for [TR-72D](#)

Example for [TR-76D](#)

SPI pins

SPI communication

If SPI is used for communication between the TR and an SPI Master, the SPI bus must solely be dedicated to this interface only. The timing requirements specified in the [IQRF SPI Technical guide](#) for continuous traffic must be observed. Therefore, sharing the bus for other purposes is not allowed.

Upload and debug

For SMT-mounted TRs, power supply pins (**Vcc** and **GND**), as well as all four **SPI pins** should **externally be accessible** (e.g. via soldering pads or a connector). This enables in-circuit wired **TR upload**, (e.g. for initial TR upload, maintenance, or troubleshooting) as well as debug while development.

Besides TR upload/debug, the SPI pins can be **shared** with external user peripherals, but a collision on these pins must be avoided. If possible, dedicate the SPI pins exclusively to upload/debug. See chapter [TR upload](#) below.

A/D pins

The maximum recommended impedance for analog sources connected to input pins of the A/D converter inside the MCU is **10 kΩ**.

IQuip prebonding tool

A user-friendly way of bonding an end Node device equipped with the NFC (contactless) communication is by the **IQuip (IQD-NFC-01)** prebonding tool. To use this, the interrupt request output from the NFC must be connected to the TR transceiver inside the end Node device:

- Either to the pin dedicated to interrupt on change (C5, Q12, or Q2, according to the TR type)
- Or to another TR pin. But polling must be used by TR instead of the interrupt in this case.

Unused pins

Unused I/Os (excluding the [do-not-use-pin](#)) must not be left as MCU digital inputs without a proper log. level otherwise the reliability and power consumption may be affected.

This can be ensured by a **pull-up** or **pull-down** resistor on each unused pin. However, there is often a possibility to do **without** such **resistors** by declaring unused pins as **digital outputs**. But, if so, consider that this must be **arranged in the application SW**, and in some situations, the application is not launched which results in leaving these pins default **floating**:

- During [RFPGM](#) (wireless upload of user application). Use external pull-ups or pull-downs if RFPGM is applicable.
- During [DSM](#) (DPA Service Mode). Declare unused pins as outputs in [IO Setup](#) within the [device startup](#) procedure in [Custom DPA Handler](#).

A do-not-use pin

SMT TRs have one pin (e.g. Q16 for [TR-76D](#)) dedicated to factory purposes. This pin must be left unconnected and not used in the user application.

3 TR upload

Wired in-circuit upload

PGM mode allowing wired upload (feeding the application code into the TR) can be invoked after TR power on only. Thus, if **wired in-circuit upload** into the TR soldered in the user equipment is required, the power source supplying the TR must be **disconnectable**. See chapters [Disconnecting](#) and [Pins to switch to programming mode](#) above and the [CK-USB-04A User's guide](#), chapter [In-circuit upload](#).

An **SDO - SDI** pair of TR pins is used as the output and input during the initial approximately 200 ms **boot-up** (after TR power supply rising-up) to detect a request to enter the programming mode (PGM). The TR is **switched to PGM** if the sequence outgoing from the output pin is completely **copied** to the input pin.

This method is utilized in IQRF development tools (e.g. controlled from IQRF IDE and the [CK-USB-04A](#) programmer, either in-circuit or for a TR plugged in SIM connector in the programmer) but can also be implemented by the user's means. See chapter [TR upload](#) in [IQRF SPI Technical guide](#).

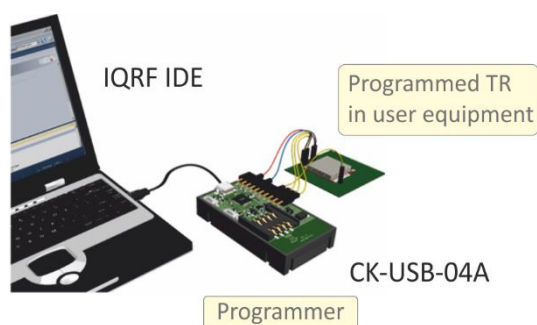

Fig.8: Wired in-circuit upload

Wireless in-circuit upload

Wireless in-circuit upload (**RFPGM**) does not require TR HW reset but it is necessary to **arrange a method** how to **invoke RFPGM**, either just by **SW** means in the application or with a help of **HW** (e.g. a **pushbutton**). See [IQRF OS User's guide](#), [Appendix RFPGM](#).

4 Application circuitry

Non-SMT TRs

Besides [decoupling capacitor\(s\)](#), the non-SMT TRs (e.g. [TR-72D](#)) typically require no external components.

However, be careful with the TR pin where the SDI is mapped (e.g. C7 for TR-72D or Q7 for TR-76D). Refer to chapter [Pins to switch to programming mode](#).

SMT TRs

However, for the highest flexibility and lowest power consumption and size, the onboard circuitry of SMT TRs (e.g. [TR-76D](#)) is reduced in comparison with non-SMT TRs. That is why some additional **external parts** (depending on the application) should be used on user HW integrating an SMT TR. This is twice important especially during **development** (for friendly design, faster debug and easier troubleshooting as well as technical support).

Recommended circuit for development is available in [TR. datasheet](#).

- Both **LEDs** should be used (but not necessarily be visible outside the case) because it is practical to watch OS and DPA “**system**” indications. It may also be very useful for possible IQRF **technical support**.
- Power supply pins (**Vcc** and **GND**) and **SPI pins** should externally be **accessible** (e.g. via soldering pads or a single-row connector). If the **RFPGM** is not applicable or functional for some reason, there will be a possibility to **upload** the TR using IQRF IDE after connecting [CK-USB-04A](#) by wires. See chapters [Pins to switch to programming mode](#) and [TR upload](#).
- If an external MCU is used, it is recommended to have an option to **disconnect** the **power supply** from TR and disconnect all TR pins by a control signal from this MCU. This allows performing **HW reset** of TR in a reliable way. See chapter [Disconnecting](#).

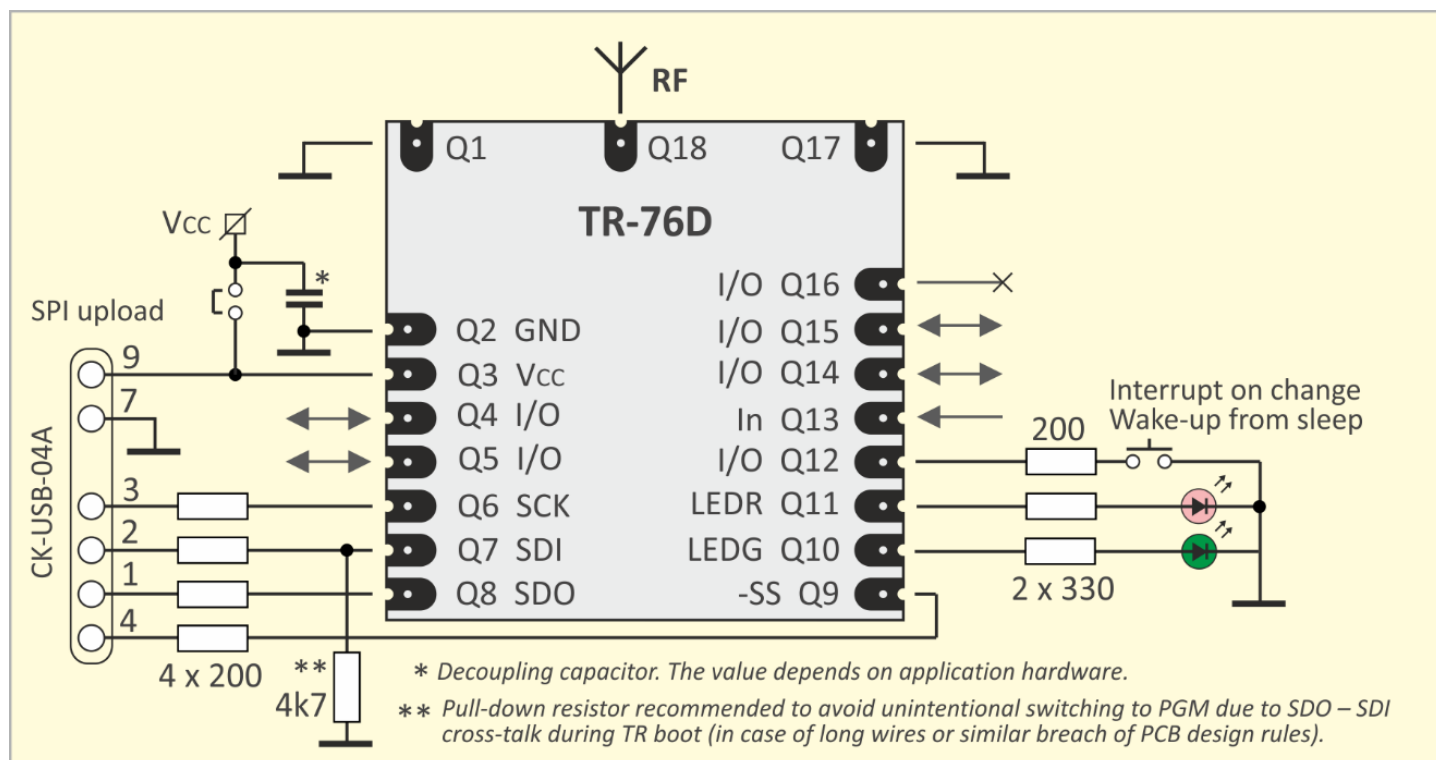

Fig.9: Example of the recommended circuit for development with [TR-76D](#).

Hint

For **mass production** of well-debugged **final** equipment, some of the external parts may be omitted. But it should be decided carefully with respect to requirements for possible subsequent maintenance and troubleshooting. E.g., LEDs may be useless if TR-76DA is sealed in an opaque case that cannot be disassembled.

5 RF aspects

RF range

Besides general principles for electronic design, additional rules regarding RF must be observed to achieve the proper RF range: **placement** of TR with respect to other circuitry on the board, **antenna position**, and **orientation** with respect to **polarization** and **radiation patterns**, PCB **ground planes**, possible **bulk objects** near the antenna, etc.

See the Application note [AN014 – RF Range](#).

Antenna design

Third-party antenna

It is possible to use antennas from 3rd party manufacturers. They should have the following features:

- **50 Ω** impedance
- **SMA** connector recommended (to fit the [CAB-U.FL/SMA](#) cable). For other antenna connections, the [CAB-U.FL](#) cable is intended.
- Antenna **gain** with respect to RF output power must comply with the local regulation.
- **Higher gain** means **higher input sensitivity** as well which may lead to a higher impact of the noise. But this influence can be eliminated by SW means (via RX filter).

However, even well-looking parameters specified in the datasheet (especially for an antenna made by a less renowned manufacturer) may result in problematic behavior, especially in networks. Thus, despite the **specifications declared on paper**, the antenna and the antenna cable **should always be checked**. The application engineer should test and tune the functionality with the TR in the application as a whole whether it suits the user's requirements and expectations. Of course, the TR must be set up correctly (e.g. RX filter).

PCB antenna

It is possible to use the user's own built-in PCB antenna. This must be designed by an RF expert. The antenna should have the **50 Ω** impedance. The range will depend on the antenna construction, location on the board with respect to the surroundings, antenna orientation, etc.

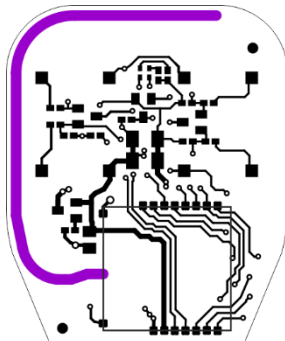

Fig.10: Example of PCB antenna

It is possible to have designed a user-specific antenna by IQRF manufacturer. Contact [IQRF support](#) for a **turn-key** solution.

Antenna connector

To connect an external antenna to a TR without onboard U.FL connector (e.g. [TR-76D](#)) via a cable and an **external coaxial connector**, the connection between the connector and the antenna pin must be **tuned to 50 Ω** impedance.

Miniature connector

For short cables the miniature **U.FL** connector [KON-U.FL-R-SMT](#) is recommended. See chapter [Antenna connector layout](#) below for recommended PCB layout.

SMA connector

For a long distance, an **SMA** connector should be used which supports a **thicker cable** with **lower attenuation**.

Antenna cable

In general, **higher cable length** and **lower cable diameter** mean **higher RF attenuation**. [CAB-U.FL/SMA](#) and [CAB-U.FL](#) cables from IQRF accessories are recommended.

A **3rd party** coaxial **50 Ω** impedance cable fitting the [KON-U.FL-R-SMT](#) connector is also possible but must be **tested** with the application as carefully as the antenna.

In both cases above, due to **parasitic reflections**, there are some **restrictions** regarding short cable lengths with respect to the given RF band. See the recommendation on [CAB-U.FL/SMA](#) product page.

RF self-noise

You should consider that possible **noise** may be coming not from the environment but may be **generated by the user wireless equipment itself** (if the HW is not designed properly).

This may be the issue especially when a **switching power supply** is used. One of the other possible causes of the noise may be a **frequency multiplier/PLL** inside an MCU (if utilized in user equipment) with respect to the frequency used.

RF noise detection software

```
// *****  
#include "iqrh.h" // System header files  
#define RX_FILTER 0 // Change according the noise level  
// *****  
void APPLICATION()  
{  
    while(1)  
    {  
        if (checkRF(RX_FILTER))  
            pulseLEDR();  
    }  
}  
// *****
```

RF self-noise test

Two tests should be performed:

- A **noise radiated** from the equipment **into the air**:

Use an external noise detector made from an additional TR transceiver (typically TR-72DA) and the [DK-EVAL-04A](#) kit as follows:

- Set desired RF band and RF channel for this TR in TR configuration.
 - Upload the RF noise detection software into this TR and plug it into the DK-EVAL-04A.
 - Place this detector to the location where the noise should be checked, e.g. close to your equipment or a power source.
 - The noise possibly radiated from the equipment is indicated by the red LED flashing.
 - Change parameter `RX_FILTER` to evaluate the noise level.
- A **noise propagated** from the equipment into the TR inside **via wires**, especially the **power lines**.
 - Upload the RF noise detection software directly into the TR inside your equipment.
 - The noise possibly incoming via wires is indicated by the red LED flashing.
 - Change parameter `RX_FILTER` to evaluate the noise level.

6 PCB design

Footprint

PCB footprint drawings for SMT TRs as well as for the [KON-SIM-02](#) and [KON-U.FL-R-SMT](#) are available in respective datasheets.

Recommended PCB layout

Additionally, recommended PCB layout for the above-mentioned parts are also provided in their datasheets. Moreover, [PCB libraries](#) according to this layout for some PCB design development systems are available as well.

However, the exact PCB layout must always be **adapted for the assembling technology** used.

These recommendations are intended through rough suggestions only. No representation or warranty is given and no liability is assumed by IQRF Tech s.r.o. with respect to the accuracy or use of such information.

Antenna connector layout

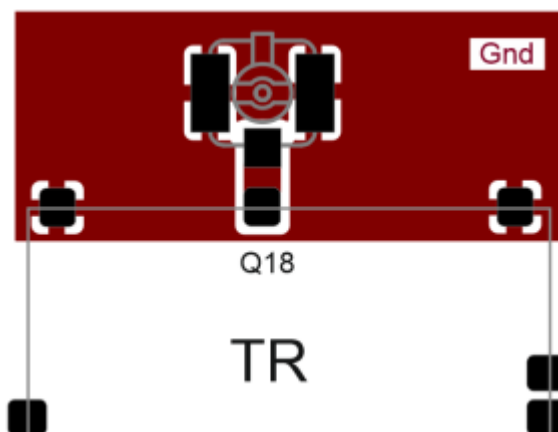

Fig.11: Recommended KON-U.FL-R-SMT layout (example for TR-76D)

3D models

[3D models](#) for TR-72D(A) and TR-76D(A) as well as for the KON-SIM-02 are available.

3D models are intended through rough guidance only. No representation or warranty is given and no liability is assumed by IQRF Tech s.r.o. with respect to the accuracy or use of such information.

7 SMT mounting

Rules and recommendations for SMT mounting

All IQRF TR modules are lead-free. For proper assembly of surface mount TR modules and avoiding damage during solder reflow, the rules mentioned below must be observed.

Perform assembly test with your actual PCB before mass production, since the temperatures of PCB surfaces vary according to the size of PCB, the status of parts mounting, and heating method.

Base PCB

Base PCB pads should be designed in accordance with the PCB layout recommended in the datasheet of the given TR module. However, it must be adapted for the mounting technology used.

Baking

The TR modules must be baked dry according to IPC/JEDEC J-STD-033C, Moisture Sensitivity Level 4 before reflow soldering.

Assembly

The TR modules must be assembled according to the IPC/JEDEC J-STD-020C standard. Only one reflow cycle with the thermal profile specified below is allowed.

Reflow profile

Recommended Pb-free thermal reflow profile for TR modules is shown in the diagram below. The actual reflow profile can depend on specific factors such as given solder reflow equipment, technology process, base PCB footprint, etc. Thus, the proper reflow profile should always be optimized and verified for given conditions.

Sn/Pb reflow with a lower temperature profile is also allowed.

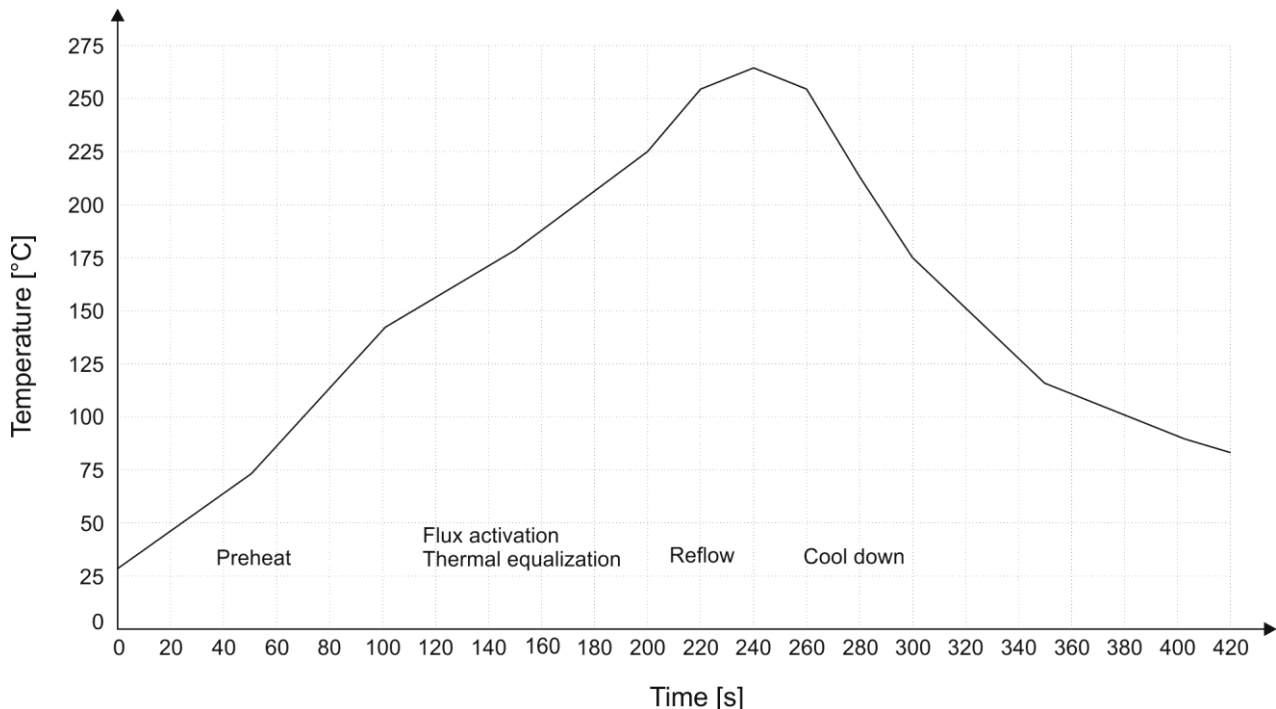

Fig.12: Reflow profile

8 Sealing

In case of **sealing** or protecting TR modules against a harsh environment by **coating**, **encapsulating**, or **potting** using a **lacquer**, **gel**, or other filling matter, the **ion cleanliness** of the TR modules must be less than $1 \mu\text{g}/\text{cm}^2$ of NaCl equivalent otherwise there is a risk of corrosion.

Such a surface treatment always impacts the **RF range**. Thus, sealing material should have a relative permeability (μ_r) as close to 1 within the given frequency band. E.g. $\mu_r=4$ at 868 MHz may decrease relative range to approx. 70% or even more but it strongly depends on the particular arrangement.

Protecting materials, methods, accomplishments, and handling must comply with general requirements and rules for proper use with electronic devices. Damaging, either chemical or mechanical (even due to the thermal expansivity of the material used) must be avoided. Testing is necessary to ensure that the application meets the specifications.

Recommended coating material: BECTRON MR 3404.

9 Case

Refer to the [Application note AN014 – RF range](#) for the impact of the product case on RF range.

10 Recommended documentation

- [1] TR datasheets:
- [TR-72D datasheet](#)
 - [TR-75D datasheet](#)
 - [TR-76D datasheet](#)
 - [TR-77D datasheet](#)

11 Document revision

- 220119 Chapter [Filtration](#) revised.
- 210712 Subchapter [SPI communication](#) added to chapter *SPI pins*. Chapter [Rules and recommendations for SMT mounting](#) are slightly extended. Chapter [Prebonding tool IQD-NFC-01](#) added.
- 200526 Chapters *Unused pins* and *Internal pull-up resistors* added. Fig.11 (recommended KON-U.FL-R-SMT layout) revised.
- 191211 First release.

12 Sales and Service

Corporate office

IQRF Tech s.r.o., Prumyslova 1275, 506 01 Jicin, Czech Republic, EU

Tel: +420 493 538 125, Fax: +420 493 538 126, www.iqrf.tech

E-mail (commercial matters): sales@iqrf.org

Technology and development

www.iqrf.org

E-mail (technical matters): support@iqrf.org

Partners and distribution

www.iqrf.org/sales/distributors

Quality management

ISO 9001 : 2016 certified

Trademarks

The IQRF name and logo are registered trademarks of IQRF Tech s.r.o.

All other trademarks mentioned herein are property of their respective owners.

Legal

All information contained in this publication is intended through suggestion only and may be superseded by updates without prior notice. No representation or warranty is given and no liability is assumed by IQRF Tech s.r.o. with respect to the accuracy or use of such information.

Without written permission it is not allowed to copy or reproduce this information, even partially.

No licenses are conveyed, implicitly or otherwise, under any intellectual property rights.

The IQRF ® products utilize several patents (CZ, EU, US)

On-line support

support@iqrf.org



Smarter Wireless. Simply.